



## Modeling of the retention of atrazine and dimethoate with nanofiltration

A.L. Ahmad\*, L.S. Tan, S.R. Abd. Shukor

School of Chemical Engineering, Engineering Campus, Universiti Sains Malaysia, 14300 Nibong Tebal, Seberang Prai Selatan, Pulau Pinang, Malaysia

### ARTICLE INFO

#### Article history:

Received 31 October 2007

Received in revised form 3 July 2008

Accepted 4 July 2008

#### Keywords:

Nanofiltration

Dimethoate

Atrazine

Organic molecules

Spiegler–Kedem

### ABSTRACT

The present study aims to investigate the viability of using Spiegler–Kedem model to predict the retention of atrazine and dimethoate with nanofiltration using NF90 in stirred cell condition. Spiegler–Kedem model is the thermodynamics of irreversible processes in which no particular mechanism of transport and structure of membrane is specified. The Spiegler–Kedem transport equations were used to derive the reflection coefficient and solute permeability of the system. The model was successfully applied on the modeling of the organic molecules tested. It was found that Spiegler–Kedem model provided a good estimation of experimental value. The coefficient of determination ( $R^2$ ) obtained for the fitted data was 0.9871 and 0.9692 for atrazine and dimethoate, respectively.

© 2008 Published by Elsevier B.V.

### 1. Introduction

Public attention on the potential long-term consequences of pesticides on human health and environment has started since 1962 when Carson [1] highlighted the matter in her book 'Silent Spring'. Ballantyne and Marrs [2] stated that the word 'pesticides' is used to cover substances that control organisms (insects, fungi, plants, slugs, snails, weeds, micro-organism, and nematodes) which destroy plant life and interfere with food chain, and which act as vectors to disease organism to man and animals. Pesticide pollution in water may arise from runoff and leaching [3,4].

The implementation on the control of water quality is important because different type of pesticides have different decaying period. Unlike heavy metals and other pollutants, pesticides are lethal to the environment even at microlevel of concentrations [5]. Nanofiltration is a promising membrane technique with a growing number of applications for the treatment of drinking water and wastewater [6]. Nanofiltration membranes differ from reverse osmosis membranes mainly because they are designed to selectively remove compounds such as multivalent ions or organic contaminants while allowing other compounds to pass [7]. Furthermore, the energy requirements are much lower for nanofiltration than with reverse osmosis because the transmembrane pressures applied in nanofiltration are significantly lower than those in reverse osmosis [8]. The nominal molecular weight cut-off of nanofiltration membranes is

in the range of 100–1000 Da [9] while pesticides have molecular weight of more than 100 [10]. Hence, nanofiltration could retain pesticides efficiently depending on characteristics of the membrane and solutes as well as interaction between them [7].

Some nanofiltration models take into account the mechanism of transport while other models are independent of the mechanism transport. The solution–diffusion model, solution–diffusion imperfection and extended Nernst–Planck model belong to the former category while the Spiegler–Kedem (SK) model represents the latter [11]. Spiegler–Kedem model is the thermodynamics of irreversible processes which indicates that the flow of each component in a solution is related to the flows of other components. In this model, the membrane is treated as a 'black box' in which no particular mechanism of transport and structure of membrane is specified [12]. It was relatively slow process near equilibrium where the mechanisms of transport and the structure of the membrane are ignored [13]. The nature of the membrane such as charge and compactness also does not affect the transport activities through it [11]. The Spiegler–Kedem model has been extensively used in predicting data for the transport of charged and uncharged solute through the membrane in nanofiltration system [6,12,14–16]. However, modeling on the retention of organic molecules has received less attention so far [6].

Atrazine was selected as subject of study because this herbicide is commonly used in the plantations around the world as well as in Malaysia [17]. Extensive amount of its usage has ranked it among the most common pesticides found in surface water and ground-water [18]. On the other hand, dimethoate is also widely used in Malaysia and it is being regulated in guidelines for drinking water by World Health Organization. Nevertheless, data on effectiveness

\* Corresponding author. Tel.: +60 4 5937788; fax: +60 4 5941013.  
E-mail address: [chlatif@eng.usm.my](mailto:chlatif@eng.usm.my) (A.L. Ahmad).

### Nomenclature

$a$	an osmotic constant ( $\text{m}^3 \text{ Pa/g}$ )
$A$	membrane area
$C_{\text{bs}}$	solute bulk concentration ( $\text{mg/L}$ )
$C_f$	concentration of feed
$C_{\text{ms}}$	solute concentration at the wall of feed side ( $\text{mg/L}$ )
$C_p$	concentration of permeate
$C_{\text{ps}}$	solute concentration at the permeate side ( $\text{mg/L}$ )
$C_s$	solute concentration in solution ( $\text{mol/m}^3$ )
$\bar{C}_s$	average solute concentration in solution ( $\text{mol/m}^3$ )
$dC_s$	solute concentration different in solution ( $\text{mol/m}^3$ )
$dx$	vertical distance from the membrane surface (m)
$D_w$	diffusion coefficient in water ( $\text{m}^2/\text{s}$ )
$J_s$	solute flux ( $\text{mol/m}^2 \text{ s}$ )
$J_v$	solvent fluxes (m/s)
$k_s$	mass transfer coefficient (m/s)
$K_{\text{ow}}$	octanol/water partition coefficient
$L_p$	membrane permeability
$m$	solute molar mass (g/mol)
$\Delta P$	hydrostatic pressure-driven difference ( $\text{N/m}^2$ )
$P_s$	solute permeability ( $\text{mol/N.s}$ )
$P_w$	hydrodynamic permeability ( $\text{m}^3/\text{N.s}$ )
$\bar{P}_s$	local solute permeability ( $\text{m}^2/\text{s}$ )
$\bar{P}_w$	specific hydraulic permeability ( $\text{m}^4/\text{N.s}$ )
$r_{\text{sc}}$	radius of stirred cell (m)
$R$	pesticide retention
$R_g$	ideal gas constant ( $8.314 \text{ m}^3 \text{ Pa/mol K}$ )
$R_s$	true rejection
$Sh$	Sherwood number
$\Delta t$	time difference
$T$	operating temperature (K)
$v_w$	permeate flux
$\Delta V$	cumulative volume difference
<i>Greek letters</i>	
$\mu$	viscosity of solution ( $\text{kg/m.s}$ )
$\Delta\pi$	osmotic pressure difference ( $\text{N/m}^2$ )
$\rho$	density of solution ( $\text{kg/m}^3$ )
$\sigma_s$	reflection coefficient
$\omega$	stirring rate ( $\text{s}^{-1}$ )

of dimethoate retention using membranes has not been found so far [19]. Previous studies [20,21] found that NF90 showed superior rejection characteristics for atrazine and dimethoate compared to other nanofiltration membranes tested. Therefore, the objective of the present study is to investigate the viability of using Spiegler–Kedem model to predict the retention of atrazine and dimethoate with NF90 in stirred cell condition. The measurable objectives are:

- (1) To estimate the parameters of the model from the experimental data obtained from the nanofiltration system.
- (2) To validate the proposed model by comparing the simulated results with the experimental results.

## 2. Theory

The Spiegler–Kedem model states that the fluxes of solute and solvent are directly related to the chemical potential differences between the two sides of the membrane. The chemical potential gradient is caused by either concentration or pressure gradient. The solvent transport is due to the pressure gradient across the mem-

brane and the solute transport is due to the concentration gradient and/or convective coupling of the volume flow [11].

### 2.1. Transport equations

The transport equation expressed by Spiegler–Kedem model is as follows [22]:

- For solvent

$$J_v = -\bar{P}_w \left( \frac{dP}{dx} - \sigma_s \frac{d\pi}{dx} \right) \quad (1)$$

- For solute

$$J_s = -\bar{P}_s \frac{dC_s}{dx} + (1 - \sigma_s) C_s J_v \quad (2)$$

Diffusion is represented by the first term in Eq. (2); the second term represents the contribution of convection to the transport of uncharged molecules [8]. In an ideally semipermeable membrane,  $\sigma = 1$ . In an entirely unselective membrane in which a concentration gradient does not cause volumetric flow at all,  $\sigma = 0$ . Thus,  $\sigma$  is a measure of the degree of semipermeability of the membrane reflecting its ability to pass solvent in preference to solute and solvent and  $\sigma = 0$  indicates complete coupling [11].

### 2.2. Model development

The transport phenomena of nanofiltration membranes in the pressure-driven process can be described by the irreversible thermodynamics. In general, the transport equations for the components through a nanofiltration membrane consist of two component which is diffusion component and convection component. This is reflected by the transport equation of Spiegler–Kedem. For a system involving a single solute in aqueous solution, the solute retention can be described by three transport coefficients:

- Specific hydraulic permeability,  $P_w$ .
- Local solute permeability,  $P_s$ .
- Reflection coefficient,  $\sigma_s$ .

Permeability is the flux of a component (solvent or solute) through the membrane per unit driving force (the effective transmembrane pressure). The reflection coefficient is a measure of the portion of the membrane through which the solute cannot be transferred [14]. The assumptions made for this work are:

- The Spiegler–Kedem model is assumed to adequately predict the transport of solutes and solvent regardless the type of solutes and its charges, solvent and membrane.
- The pressure and concentration gradient are the driving forces.
- Solutes present in the system are semipermeable to the membrane.
- In the concentration polarization layer thickness, each solute has its independent value of the diffusion and mass transfer coefficients.
- $P_w$ ,  $P_s$  and  $\sigma_s$  are assumed to be constants across the uncharged membranes so that the equation for the integration of Eqs. (1) and (2) of the membrane can be simplified.

The simplified version of model transport equation can be written as [23]:

- For solvent

$$J_v = P_w (\Delta P - \sigma_s \Delta\pi) \quad (3)$$

- For solute

$$J_s = -P_s \Delta \pi + (1 - \sigma_s) \bar{C}_s J_v \quad (4)$$

Osmotic pressure,  $\pi$ , can be estimated using the Vant-Hoff's equation [12]:

$$\Delta \pi = a(C_{ms} - C_{ps}) \quad (5)$$

$$a = \frac{R_g T}{m} \quad (6)$$

Eqs. (3) and (4) can be simplified as

$$J_v = P_w(\Delta P - \sigma_s a R_s C_{ms}) \quad (7)$$

$$J_s = -P_s a R_s C_{ms} + (1 - \sigma_s) \bar{C}_s J_v \quad (8)$$

The imperfection of the membrane is characterized by the reflection coefficient,  $\sigma_s$ . This reflection coefficient can express the degree of solute–membrane interaction whose values are in the range of  $0 \leq \sigma_s \leq 1$ . An osmotic difference ( $\Delta \pi$ ) across an imperfectly semipermeable membranes is compensated by an applied pressure ( $\Delta P$ ) so that the solvent flux is zero ( $J_v = 0$ ) and  $\Delta P$  is smaller than  $\Delta \pi$ . The ratio between these two is defined as  $\sigma$ .

$$\sigma = \left( \frac{\Delta P}{\Delta \pi} \right)_{J_v=0} \quad (9)$$

where  $\sigma = 1$ , for in ideally semipermeable membrane (100% rejection) and  $\sigma = 0$ , no rejection.

Reflection coefficient,  $\sigma$ , is characteristic of the convective transport of the solute. An  $\sigma$  of 100% indicates that the convective solute transport is totally hindered or that no transport by convection takes place at all. This is the case for ideal RO membranes where the membranes have a dense structure and no pores are available for convective transport. The retention may however be lower than 100% because solute transport may take place by solution–diffusion. As it has been shown that nanofiltration membranes have pores, a reflection coefficient below 100% will be found if the solutes are small enough to enter the membrane pores.

The Spiegler–Kedem model assumes the membrane to be uncharged. In neutral membranes, solute permeability,  $P_s$  and the reflection coefficient,  $\sigma$  have constant values characterizing a given solute–membrane system. At low pressure, both terms contribute to the transport of solute through the membrane. However, at higher pressure, the relative importance of convection in the transport will be higher. In the hypothetical case of an infinite pressure, diffusion is negligible compared to the infinite convection flux. Since diffusion of solutes will result in an increase of transport relative to the water transport, the relative transport solutes is at the lowest at infinite pressure. The permeation for solute is defined as [12]:

$$R_s = 1 - \frac{C_{ps}}{C_{ms}} \quad (10)$$

The true rejection in term of reflection coefficient,  $\sigma$  and solute driving force,  $F_s$

$$R_s = \frac{\sigma_s(1 - F_s)}{1 - \sigma_s F_s} \quad (11)$$

where  $F_s$  is defined as

$$F_s = \exp\left(-\frac{(1 - \sigma_s) J_v}{P_s}\right) \quad (12)$$

The observed retention coefficient,  $R_{os}$  is defined by the solute concentration in feed,  $C_{fs}$  and the permeate  $C_{ps}$

$$R_{os} = 1 - \frac{C_{ps}}{C_{fs}} \quad (13)$$

As the Spiegler–Kedem model relates the membrane surface concentration to the permeate concentration, it needs to be combined with concentration polarization if the permeate concentration is to be related to the bulk feed concentration. This results in the Combined Film Theory–Spiegler–Kedem or CFSK models. This phenomenon is expressed in the Film Theory Model [12]. Mass transfer coefficient,  $k_s$ , is an important parameter for concentration polarization where this parameter is dependent on several factor like feed flow rate, temperature and cell geometry.

Relationship between membrane surface concentration to the permeate concentration in concentration polarization is expressed in Eq. (14). The concentration polarization usually exists in nanofiltration process because of the formation of a boundary layer separating the membranes surface from the bulk solution [12].

$$\frac{C_{ms} - C_{ps}}{C_{bs} - C_{ps}} = \exp\left(\frac{J_v}{k_s}\right) \quad (14)$$

which  $k_s$  is defined as

$$k_s = \frac{D_{sw}}{\delta} \quad (15)$$

where  $D_{sw}$  is the diffusion coefficient of solute in water and  $\delta$  is the concentration polarization layer thickness. By using the rejection fractions instead of concentrations, the Film Theory Model can be expressing as

$$\frac{R_{os}}{1 - R_{os}} = \frac{R_s}{1 - R_s} \exp\left(-\frac{J_v}{k_s}\right) \quad (16)$$

By substituting Eq. (11) into Eq. (16):

$$\frac{R_{os}}{1 - R_{os}} = \frac{\sigma_s(1 - F_s)}{1 - \sigma_s} \exp\left(-\frac{J_v}{k_s}\right) \quad (17)$$

Substitute Eqs. (12)–(17) gives

$$\frac{R_o}{1 - R_o} = \frac{\sigma}{1 - \sigma} \left[ 1 - \exp\left(-\frac{J_v(1 - \sigma)}{P_s}\right) \right] \left[ \exp\left(-\frac{J_v}{k_s}\right) \right] \quad (18)$$

On the other hand, the following equation is applied for estimation of diffusion coefficient in water,  $D_w$  [24]:

$$D_w = \frac{2.7 \times 10^{-4}}{m^{0.71}} \quad (19)$$

Meanwhile, for estimation for mass transfer coefficient,  $k_s$  [25]:

$$k_s = \frac{Sh D_w}{r_{sc}} \quad (20)$$

Sherwood number,  $Sh$ :

$$Sh = a Re^b Sc^c \quad (21)$$

Reynold number,  $Re$ :

$$Re = \frac{\rho \omega r_{sc}^2}{\mu} \quad (22)$$

Schmidt number,  $Sc$ :

$$Sc = \frac{\mu}{\rho D_w} \quad (23)$$

### 3. Experimental

#### 3.1. Materials

Dimethoate with 99.8% purity and atrazine with 97.4% purity were purchased from Riedel-de Haen (Germany). The molecular structures and properties of both pesticides are presented in Table 1. The nanofiltration membrane used in this study is NF90 (Dow/Filmtec). Table 2 provides the specification of the membrane used as given by the manufacturers.

**Table 1**  
Properties of dimethoate and atrazine [10]

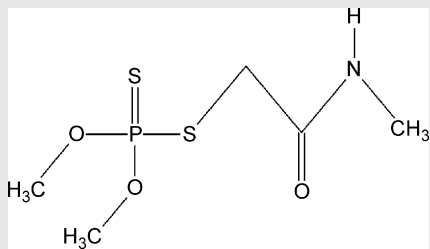
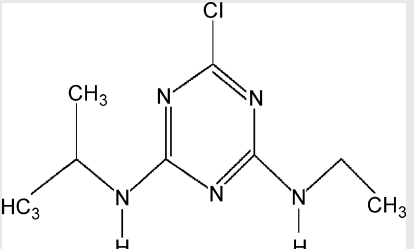
Pesticide	Dimethoate	Atrazine
Chemical structure		
Molecular weight (Da)	229.28	215.69
Solubility in water	25 g/L at 21 °C	20 mg/L at 20 °C
log $K_{ow}$	0.70	2.61 <sup>a</sup>

<sup>a</sup> Ref. [28].

### 3.2. Membrane stirred cell

A 300 mL stirred cell (Sterlitech), model Sterlitech™ HP4750, USA, was used to conduct the dead-end filtration experiments. The effective membrane area is  $1.46 \times 10^{-3} \text{ m}^2$ . The maximum operating pressure for this cell was  $69 \times 10^5 \text{ Pa}$ .

### 3.3. Experimental set-up and procedure

Dead-end filtration experiments were carried out with the stirred cell (Sterlitech™ HP4750). The pesticide solution in the cell was stirred by a Teflon-coated magnetic bar. The cell was pressur-

ized using compressed high purity nitrogen gas. The pressure in the permeate side was approximately atmospheric under all condition. The feed pesticide and stirring rate were kept constant at 10 mg/L and 1000 rpm while the operating pressure were varied from  $5 \times 10^5$  to  $15 \times 10^5 \text{ Pa}$ . Although the range of usual run-off case is in  $\mu\text{g/L}$ , the range of concentration used in this study is in mg/L as to consider on case of accidental spill of pesticides in water source as well. The membrane was immersed for 24 h in deionized water before being used in any experimental work. Membrane permeability was determined by initially filtering it using deionized water at  $16 \times 10^5 \text{ Pa}$  for approximately 8 h for compaction to avoid compression effect in the later stage of experiment. Then, stabilized water flux at different operating pressures was obtained and membrane permeability values ( $L_p$ ) could be determined from the slope of flux against pressure graph.

For separation process, the same compaction process was carried out before the test cell was emptied and 1.8 L of feed solution was filled into the test cell and solution reservoir. The cell was then pressurized at the operating pressure indicated by a pressure regulator. Permeate from the bottom of the cell was collected and its weight was measured with an electronic balance of  $\pm 0.01 \text{ g}$  accuracy. The cumulative weight were converted to cumulative volume and the permeate flux could be obtained. Permeate flux,  $v_w$

**Table 2**  
Specification of membrane used

Membrane	NF90
Manufacturer	Dow/Filmtec
Material	Polyamide
Pure water permeability <sup>a</sup> ( $\text{m}^3/(\text{m}^2 \text{ s Pa})$ )	$1.90 \times 10^{-11}$
Maximum operating pressure (Pa)	$41 \times 10^5$
Maximum operating temperature (°C)	45
pH range	3–10

<sup>a</sup> Our measurements.

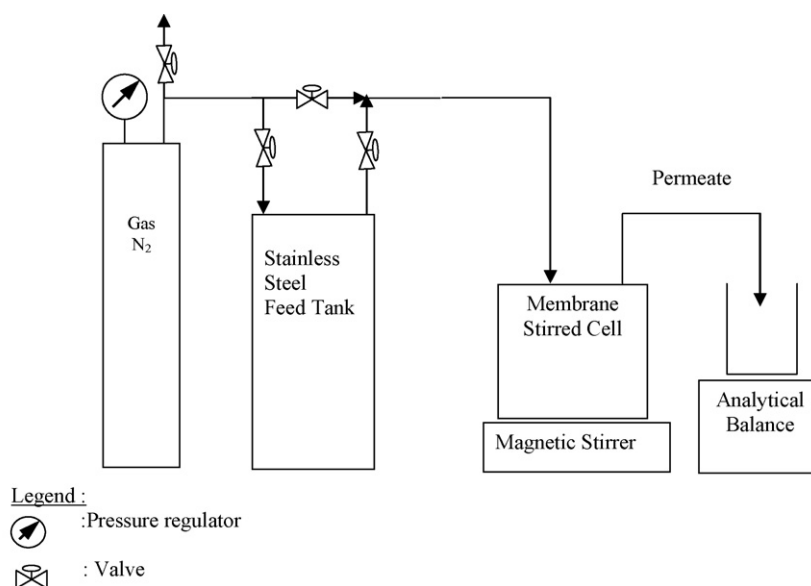

**Fig. 1.** Diagram of experimental set-up.

( $\text{m}^3/\text{m}^2 \text{ s}$ ), was obtained using equation (24):

$$v_w = \frac{\Delta V}{A \Delta t} \quad (24)$$

where  $\Delta V$  is the cumulative volume difference ( $\text{m}^3$ ),  $\Delta t$  the time difference (s) and  $A$  is the membrane area ( $\text{m}^2$ ), respectively.

Samples were collected at every 20 min for four times and the average values obtained from the samples were used as the results in this work. All experiments were conducted at room temperature ( $25 \pm 2^\circ\text{C}$ ). A schematic diagram of the experimental set up is shown in Fig. 1.

### 3.4. Analytical method

Concentration of atrazine and dimethoate in feed and permeate was analysed using high performance liquid chromatography (HPLC) by PerkinElmer (USA). The concentration of pesticides was interpreted through the area of peak shown by the system. The HPLC column used was Zorbax SB-CN ( $5 \mu\text{m}$ ,  $4.6 \text{ mm i.d.} \times 150 \text{ mm}$  long, Agilent Technologies). The mobile phase was a mixture of 35% acetonitrile and 65% deionized water while the flow rate was set at  $1.0 \text{ mL/min}$ . The UV detector was operated at a wavelength of  $200 \text{ nm}$ . The peak for dimethoate was detected at around  $3.5 \text{ min}$  while the peak for atrazine was detected at around  $5.3 \text{ min}$ . The value of retention was obtained with the following equation:

$$R = \left(1 - \frac{C_p}{C_f}\right) \quad (25)$$

where  $R$  is the pesticide retention,  $C_p$  the concentration of permeate ( $\text{mg/L}$ ) and  $C_f$  is the concentration of feed ( $\text{mg/L}$ ).

## 4. Results and discussions

### 4.1. Parameter estimation

The estimation of parameters for the membrane transport model is an important aspect of this study. The results obtained from the experimental test of the membrane system were employed for parameter estimation for the model. The Spiegler–Kedem model was characterized by the hydraulic permeability of the membrane,  $P_w$ , reflection coefficient,  $\sigma$ , solute permeability,  $P_s$  and mass transfer coefficient,  $k_s$ . Result of the parameter estimation for NF90 is shown in Table 3.

The retention of pesticide against permeate flux curve is presented in Fig. 2. It can be seen from the comparison between the experimental data and predicted data that the Spiegler–Kedem model provided good regression based on the model applied. Thus, the parameters estimated can be accepted. In fact, the coefficient of determination ( $R^2$ ) obtained for the fitted data was  $0.9871$  and  $0.9692$  for atrazine and dimethoate, respectively.

The reflection coefficient,  $\sigma$ , was in good agreement with the results obtained in the experimental work as it showed that NF90 had the value of an almost ideal membrane. This is because the value close to 1 meant that it had high ability to pass solvent in preference to solute [22], resulting in high retention of solute by

NF90. Meanwhile, atrazine had slightly higher mass transfer coefficient than dimethoate due to its slightly lower molecular weight [24]. However, atrazine had obviously lower solute permeability,  $P_s$ , compared to dimethoate. This lower solute permeability value possessed by atrazine explains its higher retention compared to dimethoate. This behaviour was due to the higher hydrophobicity ( $\log K_{ow}$ ) and heterocyclic aromatic structure of atrazine [20].

### 4.2. Comparison between experimental and modeling data

As confirmed by the irreversible thermodynamics model, the retention of solute increased with the increasing permeate flux (i.e. increasing applied pressure). The solute retention and permeate flux are plotted against applied pressure in Figs. 3 and 4, respectively. It is observed that while the solute retention against pressure curve for predicted value by Spiegler–Kedem model fitted well with the experimental data, the model was unable to match the slope of the experimental flux against pressure curve as good as it did in the case for retention. However, the trend of experimental data was still in agreement with the predicted data by the model and did not deviate far from each other.

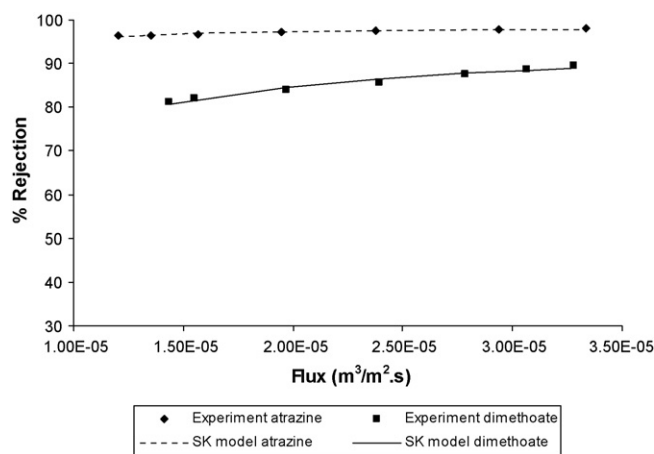

Fig. 2. Solute retention against permeate flux curve from experimental data and the predicted results from Spiegler–Kedem model.

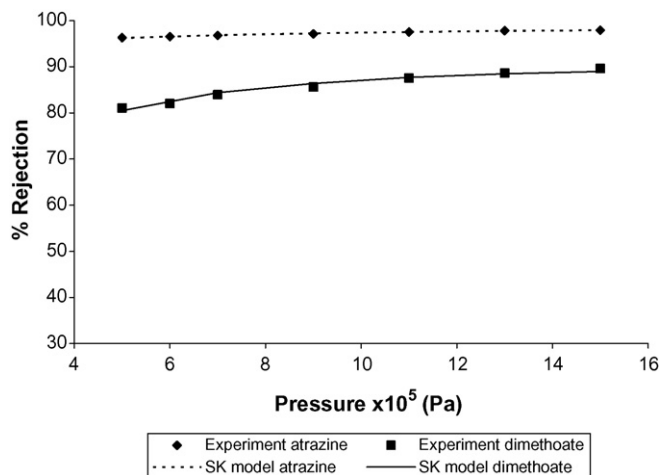

Fig. 3. Solute retention plotted against pressure using the experimental data and predicted results from Spiegler–Kedem model.

Table 3  
Parameters estimated based on the experimental results

Parameter	Value	
	Atrazine	Dimethoate
Hydraulic permeability ( $P_w$ )	$2.3611\text{E}-11$	$2.3611\text{E}-11$
Reflection coefficient ( $\sigma$ )	$0.9835$	$0.9560$
Solute permeability ( $P_s$ )	$3.4317\text{E}-07$	$2.4142\text{E}-06$
Mass transfer coefficient ( $k_s$ )	$1.2894\text{E}-05$	$1.2524\text{E}-05$

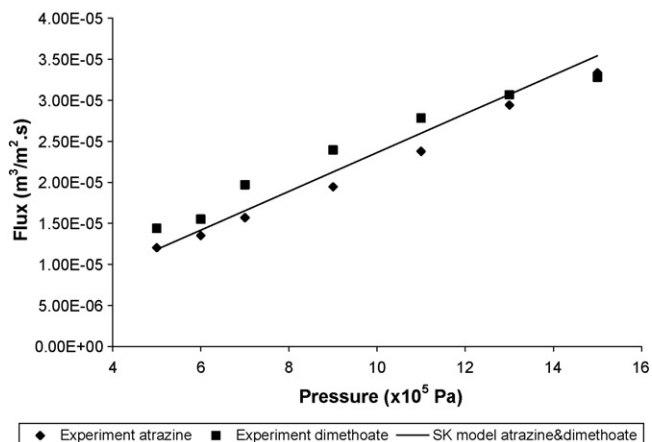

Fig. 4. Permeate flux plotted against pressure using the experimental data and predicted results from Spiegler–Kedem model.

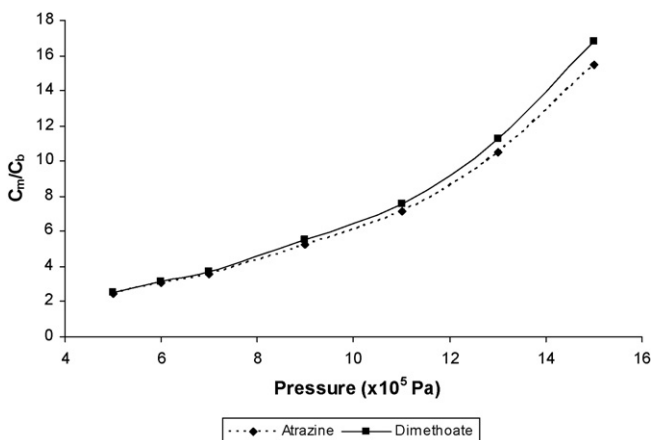

Fig. 5. Concentration polarization profile plotted against pressure.

#### 4.3. Concentration polarization profile

Fig. 5 provides the concentration polarization profiles for atrazine and dimethoate at different operating pressure. The profiles were gauged based on the ratio of membrane wall concentration to bulk concentration ( $C_m/C_b$ ) [26]. Based on the membrane wall concentration calculated from the Film Theory Model, the concentration polarization profile was depicted to increase with the increasing pressure. Both solutes demonstrated similar trends on concentration polarization where the solute concentrations increased from the initial bulk concentration to the maximum concentration (wall concentration) at the maximum pressure applied. Although previous results showed that the retention increased with the increasing pressure, these profiles show that the effect of concentration polarization would be magnified with the increasing pressure. The same trend was also observed by [27]. Thus, due consideration should be given when choosing the suitable applied pressure for nanofiltration system.

## 5. Conclusions

Comparisons were made between the Spiegler–Kedem model with the experimental data obtained for nanofiltration of atrazine and dimethoate. The model was successfully applied on the modeling of the organic molecules tested. It was found that

Spiegler–Kedem model provided a good estimation of the experimental value. The coefficient of determination ( $R^2$ ) obtained for the fitted data was 0.9871 and 0.9692 for atrazine and dimethoate, respectively. Although the model was unable to match the slope of the experimental flux against pressure curve as good as it did for the case for retention, the trend of experimental data was still in agreement with the predicted data by the model and did not deviate far from each other. It was also found from concentration polarization profiles that the effect of concentration polarization would be magnified with the increasing pressure.

## Acknowledgements

Authors would like to thank Universiti Sains Malaysia for funding this research with Short Term Grant (Account 6035167). Appreciation also goes to Dow/Filmtec for providing the membrane.

## References

- [1] R. Carson, Silent Spring, Houghton Mifflin, Boston, 1962.
- [2] B. Ballantyne, T.C. Marrs, Pesticides: an overview of fundamentals, in: B. Ballantyne, T.C. Marrs (Eds.), Pesticide Toxicology and International Regulation, John Wiley and Sons, England, 2004.
- [3] J.L. Schnoor, Chemical fate and transport in the environment, in: J.L. Schnoor (Ed.), Fate of Pesticides and Chemicals in the Environment, John Wiley and Sons, United States of America, 1992.
- [4] H. Beitz, H. Schmidt, F. Herzel, Occurrence, toxicological and ecotoxicological significance of pesticides in groundwater and surface water, in: H. Borner (Ed.), Pesticides in Groundwater and Surface Water, Springer-Verlag, Germany, 1994.
- [5] S. Yedla, A.K. Dikshit, Abatement of Pesticide Pollution: Removal of Organochlorine Pesticide from Water Environment, Narosa Publishing House, New Delhi, 2005.
- [6] B. Van der Bruggen, C. Vandecasteele, Modelling of the retention of uncharged molecules with nanofiltration, Water Res. 36 (2002) 1360–1368.
- [7] K. Kosutic, B. Kunst, Removal of organics from aqueous solutions by commercial RO and NF membranes of characterized porosities, Desalination 142 (2002) 47–56.
- [8] B. Van der Bruggen, J. Schaep, D. Wilms, C. Vandecasteele, A comparison of models to describe the maximal retention of organic molecules in nanofiltration, Sep. Sci. Technol. 35 (2000) 169–182.
- [9] D.L. Oatley, B. Cassey, P. Jones, R. Bowen, Modelling the performance of membrane nanofiltration—recovery of a high-value product from a process waste stream, Chem. Eng. Sci. 60 (2005) 1953–1964.
- [10] M.A. Kamrin, Pesticide Profiles: Toxicity, Environmental Impact, and Fate, CRC Press, Boca Raton, 1997.
- [11] A. Bhattacharya, P. Ghosh, Nanofiltration and reverse osmosis membranes: theory and application in separation of electrolytes, Rev. Chem. Eng. 20 (2004) 111–173.
- [12] A.L. Ahmad, M.F. Chong, S. Bhatia, Mathematical modelling and simulation of multiple solutes system for nanofiltration process, J. Membr. Sci. 253 (2005) 103–115.
- [13] D. Van Gauwbergen, J. Baeyens, Modelling reverse osmosis by irreversible thermodynamics, Sep. Purif. Technol. 13 (1998) 117–128.
- [14] S. Wadley, C.J. Brouckaert, L.A.D. Baddock, C.A. Buckley, Modelling of nanofiltration applied to the recovery of salt from waste brine at a sugar decolourisation plant, J. Membr. Sci. 102 (1995) 163–175.
- [15] H. Al-Zoubi, N. Hilal, N.A. Darwish, A.W. Mohammad, Rejection and modelling of sulphate and potassium salts by nanofiltration membranes: neural network and Spiegler–Kedem model, Desalination 206 (2007) 42–60.
- [16] V.K. Gupta, S.T. Hwang, W.B. Krantz, A.R. Greenberg, Characterization of nanofiltration and reverse osmosis membrane performance for aqueous salt solutions using irreversible thermodynamics, Desalination 208 (2007) 1–18.
- [17] L.K. Chooi, Personal communication, May 27, 2005.
- [18] K.V. Plakas, A.J. Karabelas, T. Wintgens, T. Melin, A study of selected herbicides retention by nanofiltration membranes—the role of organic fouling, J. Membr. Sci. 284 (2006) 291–300.
- [19] World Health Organization, Guidelines for Drinking-Water Quality, third ed., 2004, [http://www.who.int/water\\_sanitation\\_health/dwg/gdwq3/en/index.html](http://www.who.int/water_sanitation_health/dwg/gdwq3/en/index.html). Accessed on June 16, 2005.
- [20] A.L. Ahmad, L.S. Tan, S.R. Abd, Shukur, Dimethoate and atrazine retention from aqueous solution by nanofiltration membranes, J. Hazard. Mater. 151 (2008) 71–77.
- [21] A.L. Ahmad, L.S. Tan, S.R. Abd, Shukur, The role of pH in nanofiltration of atrazine and dimethoate from aqueous solution, J. Hazard. Mater. 154 (2008) 633–638.
- [22] K.S. Spiegler, O. Kedem, Thermodynamics of hyperfiltration (reverse osmosis): criteria for efficient membranes, Desalination 1 (1966) 311–326.
- [23] Z.V.P. Murthy, S.K. Gupta, Estimation of mass transfer coefficient using a combined nonlinear membrane transport and film theory model, Desalination 109 (1997) 39–49.

- [24] R.P. Schwarzenbach, P.M. Gschwend, D.M. Imboden, *Environmental Organic Chemistry*, John Wiley & Sons, New York, 1993.
- [25] A.G. Fane, Module design and operation, in: A.I. Schafer, A.G. Fane, T.D. Waite (Eds.), *Nanofiltration-Principles and Application*, Elsevier, Oxford, 2005.
- [26] A.L. Ahmad, M.F. Chong, S. Bhatia, Mathematical modeling of multiple solutes system for reverse osmosis process in palm oil mill effluent (POME) treatment, *Chem. Eng. J.* 132 (2007) 183–193.
- [27] C. Bhattacharjee, S. Datta, Analysis of polarized layer resistance during ultrafiltration of PEG-6000: an approach based on filtration theory, *Sep. Purif. Technol.* 33 (2003) 115–126.
- [28] Y. Kiso, Y. Nishimura, T. Kitao, K. Nishimura, Rejection properties of non-phenylic pesticides with nanofiltration membranes, *J. Membr. Sci.* 171 (2000) 229–237.